

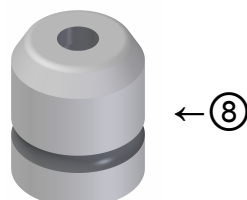

Stat. "A"
 d. max 12,7

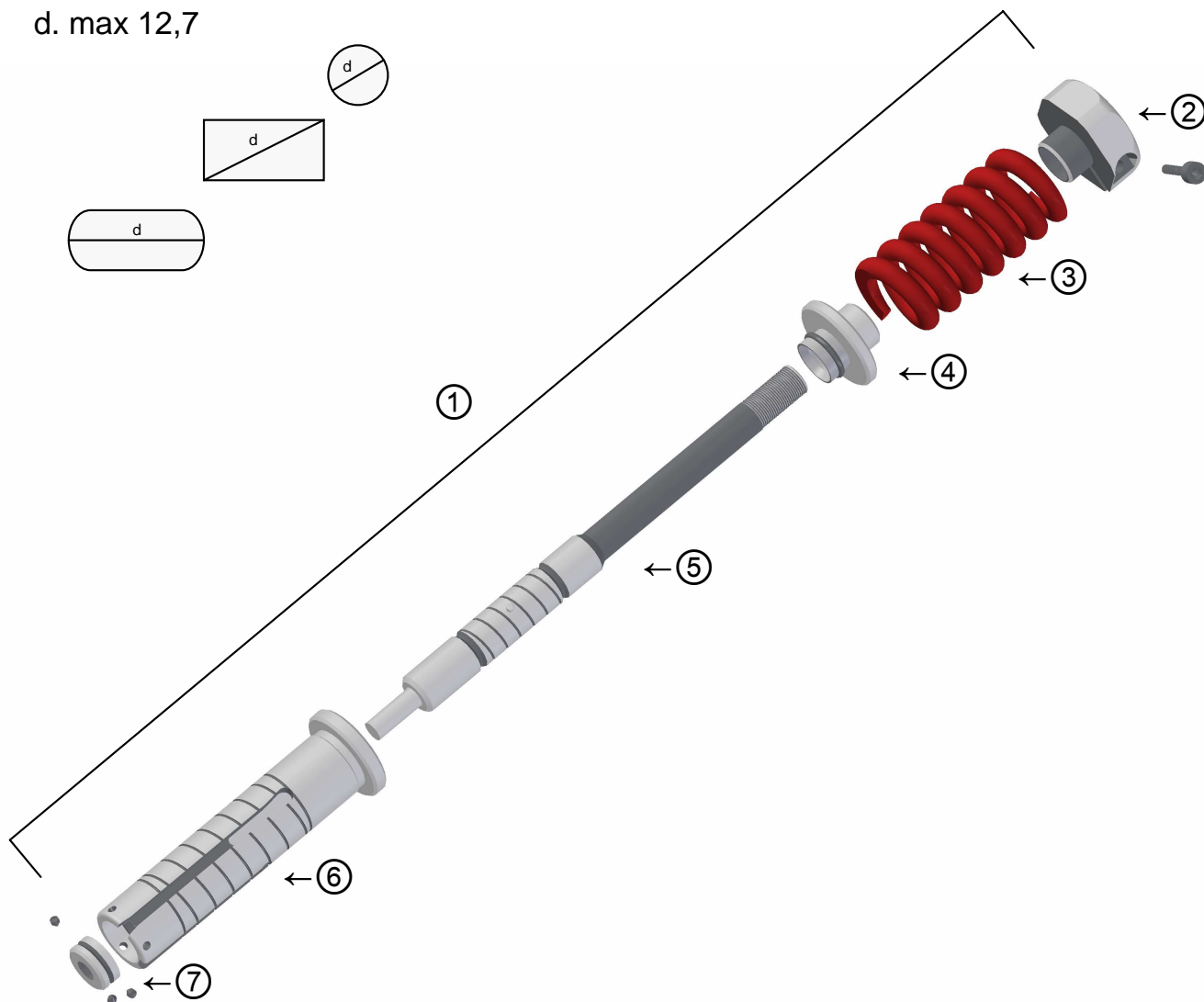

Ref.	Cod.	DESCRIZIONE / Description
1	9001	PUNZONE COMPLETO Punch ass'y
2	BM01	BATTIMAZZA Punch head
3	MA01	MOLLA Spring
4	CL01	COLLARE COMPLETO O-RING Retainer collar with o-ring
5	901	PUNZONE Punch
6	G01	GUIDA Punch guide
7	E01	DISCO ESTRATTORE Stripper plate
8	401	MATRICE Die

UTENSILI PER MACCHINE AMADA – FINN POWER – Tools for Amada – Finn Power machines

© 2014



Ciemme
 s.r.l.

Via Masaccio n.24 – 56010 – Lugnano (PI) – Italy
 Tel.050/703321 - 703411 Fax 050/703322
 www.ciemmegi.it E-mail: cmg@ciemmegi.it





Note tecniche:

- Guide temprate , rinvenute , con riferimenti standard 0°/90° per punzoni ovali e rettangoli – 0°/135° per punzoni quadrati
- Matrici antisfrido secondo richiesta
- Punzoni in acciaio HSS temprati con ricottura ad induzione della parte filettata per evitare rotture.

Su richiesta :

- Versione per macchine con lubrificazione automatica
- Riferimenti speciali
- Punzoni in acciaio SSK per lavorazioni gravose
- Rivestimenti TIN - TIALN
- Versione con taglio-punzone guidato per dimensioni di taglio molto ridotte a rischio di rottura .



Stat. "A"

Art. 9001 - 401

Ø max 12,7



Technical notes:

- Hardened, tempered guides with standard references 0°/90° for oval and rectangular punches- 0°/135° for square punches
- Anti-scrap dies as per request
- Hardened HSS punches with induction annealing of the threaded part to avoid breakings.

On request :

- Version for machines with automatic lubrication
- Special references
- Special SSK punches for heavy workings
- TIN –TIALN coatings
- Version with guided punch cutting for very small cutting dimensions in order to avoid breakings

