

Stat. "A"
d. max 12,7

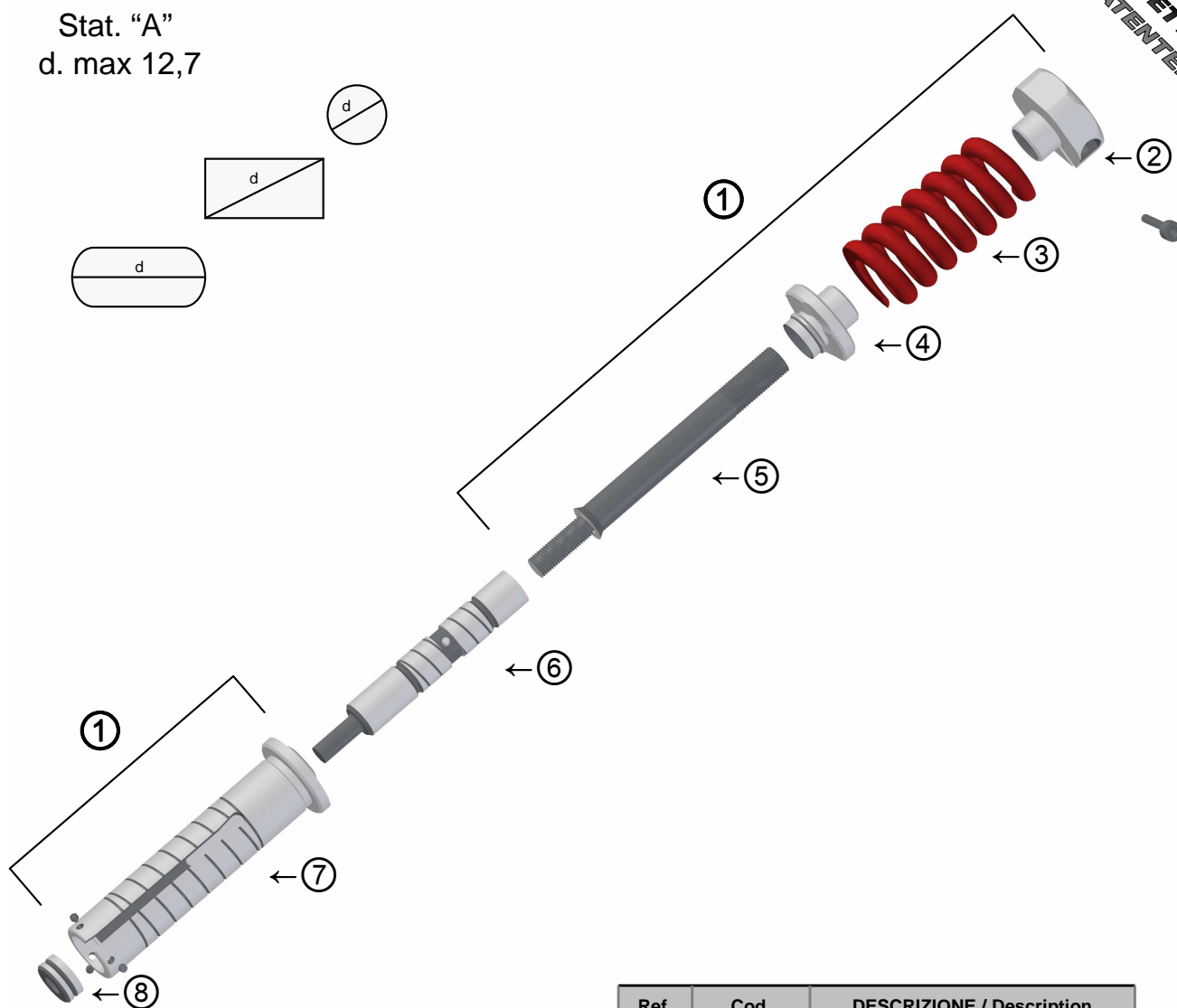

Ref.	Cod.	DESCRIZIONE / Description
1	9001FBL	GRUPPO PREASSEMBLATO (senza punzone e disco estraattore) Set ass'y (without punch and stripper plate)
2	BM01	BATTIMAZZA Punch head
3	MA01	MOLLA Spring
4	CL01FBL	COLLARE COMPLETO DI O-RING Retainer collar with o-ring
5	CD01FBL	CODOLO Spigot
6	901FBL	PUNZONE Punch
7	G01FBL	GUIDA Punch guide
8	E01	DISCO ESTRATTORE Stripper plate
9	401	MATRICE Die



**BREVETTATO
PATENTED**

Note tecniche:

- Recupero affilatura rapido senza ausilio di chiavi , regolazione minima 0,2 mm.
- Guide temprate , rinvenute , con riferimenti standard 0°/90° per punzoni ovali e rettangoli – 0°/135° per punzoni quadrati
- Matrici antisfrido secondo richiesta
- Punzoni in acciaio HSS temprati.

Su richiesta :

- Versione per macchine con lubrificazione automatica
- Riferimenti speciali
- Punzoni in acciaio SSK per lavorazioni gravose
- Rivestimenti TIN - TIALN
- Versione con taglio-punzone guidato per dimensioni di taglio molto ridotte a rischio di rottura .



Stat. "A"

Art. 9001FBL - 401

d.max 12,7



Technical notes:

- Fast sharpening recovery without wrenches, min. adjustment 0,2 mm.
- Hardened, tempered guides with standard references 0°/90° for oval and rectangular punches- 0°/135° for square punches
- Anti-scrap dies as per request
- Hardened HSS punches.

On request :

- Version for machines with automatic lubrication
- Special references
- Special SSK punches for heavy workings
- TIN –TIALN coatings
- Version with guided punch cutting for very small cutting dimensions in order to avoid breakings

